

PITUMEC

THE PCON-E 240 CONCENTRIC UNDERREAMING SYSTEM

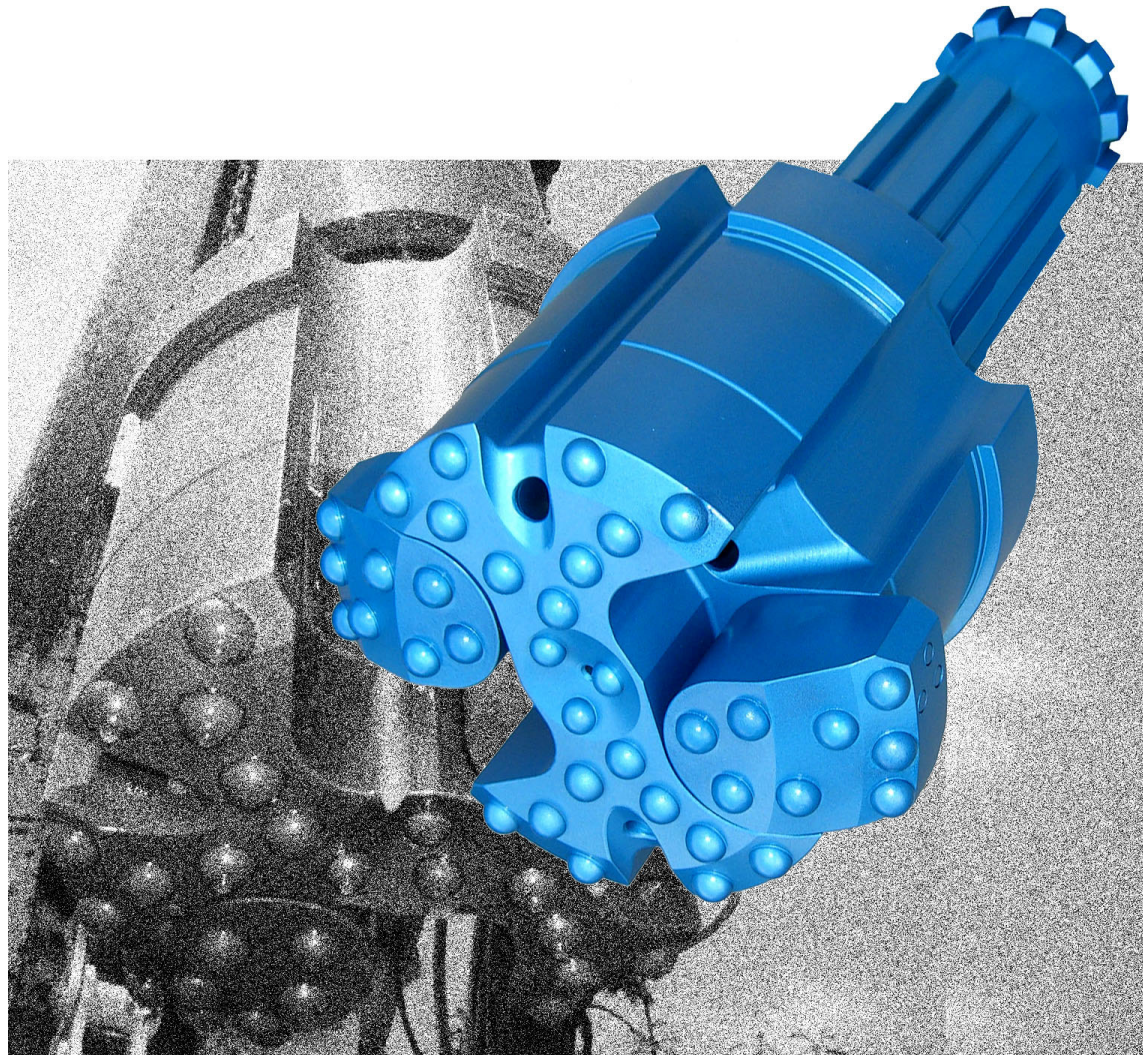

CASING SIZE 273MM OD X 260MM ID DRILLING DIA. 293MM

PNEUMEC PCON-E 240 CONCENTRIC UNDERREAMING SYSTEM

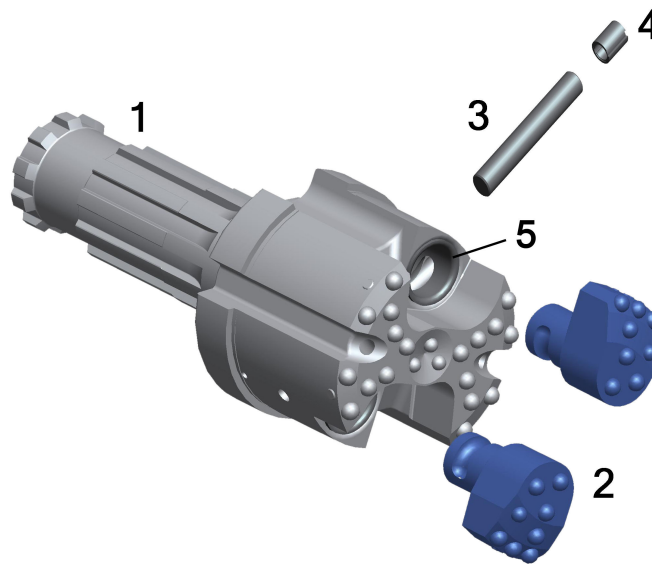

PCON-E 240 PARTS LIST

1.	DRIVER BIT DHD380 SHANK	UGD240380PCE
2.	REAMER (2)	UBS240PCE
3.	LOCKING PIN	USP24050PCE
4.	SPLIT PIN	USP24051PCE
5.	REAMER BUSH (2)	USP24054PCE
6.	COMPLETE SYSTEM DHD380 SHANK	UCS240380PCE

PCON-E 240 SPECIFICATIONS

UPPER BODY DIAMETER	256MM	CLOSED DIAMETER	241MM
REAMING DIAMETER	293MM	CASING SIZE	273MM OD X 260MM ID
SYSTEM LENGTH	590MM	SYSTEM WEIGHT	100KG

PCON-E 240 CASING SHOES

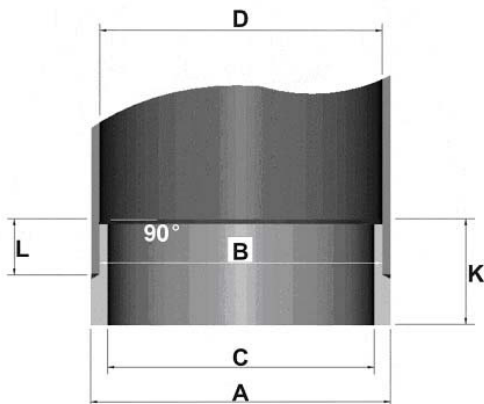

DIA. A	273MM
DIA. B	256MM
DIA. C	242MM
DIA. D	260MM
L	44MM
K	95MM



PNEUMEC COMPANY LIMITED

1st Floor, Tin On Sing Comm. Bldg., 41-43 Graham St. Central, H.K.

Tel : (852) 2180 9922

Fax : (852) 2180 9982

Website : www.pneumec.com

email : info@pneumec.com